

Subplate Mounted Heavy Duty Valve

Series 3760

Patent # 2.696.219

Features

- ▶ Original Shear-Seal® technology
- ▶ Convenient sub-plate manifold mounting
- ▶ Low pressure drop
- ▶ High velocity flow
- ▶ Tolerates contaminants
- ▶ Low handle load at high pressures

Applications

- ▶ Steel mills
- ▶ Shipboard hydraulic control systems
- ▶ Refineries and chemical processing plants
- ▶ Power generation facilities



General Specifications*

Working Pressure:	Hydraulic oil or lubricated water up to 4,500 psi (310 bar)
Flow Capacity, Cv:	See table
Back Pressure:	Must not exceed 250 psi (17.2 Bar) at return port for satisfactory operation
Pressure Drop:	14 psi (0.96 bar) at 20 ft/sec * See Supplemental Guide for more detailed information
Proof Pressure:	1-1/2 times working pressure except at return port
Burst Pressure:	2-1/2 times working pressure except at return port (3,000 psi [206 bar])
Media Temperature Range:	-40° to +250°F (-40° to +121°C)

Wetted Material:	
Rotor:	400 series stainless steel
Pressure Seals:	Stainless steel
Shaft:	Stainless steel
Body:	Bronze
Housing:	Ductile iron
Standard O-rings:	Buna N, others available
Back-up Rings:	Teflon®
Subplates: (Optional)	Carbon steel

* See product configurator for additional options.

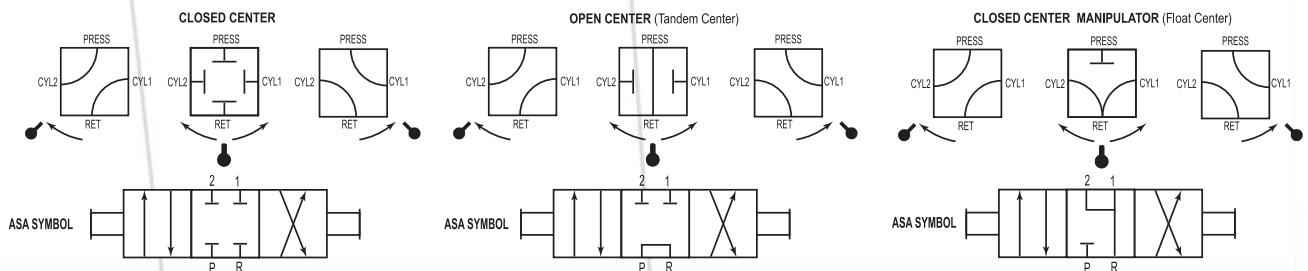

	Main Valve Port Size	Flow Capacity (Approx.)			Min. Flow Passage Dia.	Cv Factor	Approx. Shipping Weight lbs (kgs)
		Service: Oil and Lubricated Water					
		20 ft/sec gpm (l/min)	40 ft/sec gpm (l/min)	60 ft/sec gpm (l/min)			
3760 Series Valve	1/2"	9 (34)	19 (72)	28 (106)	7/16"	3.20	8.5 (4.5)
	1"	25 (95)	50 (189)	75 (284)	23/32"	9.20	24 (10.9)
	1-1/2"	57 (217)	114 (433)	171 (650)	1-3/32"	21.00	53 (24)

Barksdale
CONTROL PRODUCTS

Barksdale, Inc./Barksdale GmbH
A Subsidiary of Crane Co.



Subplate Mounted Heavy Duty Valve

Series 3760

Technical Drawings

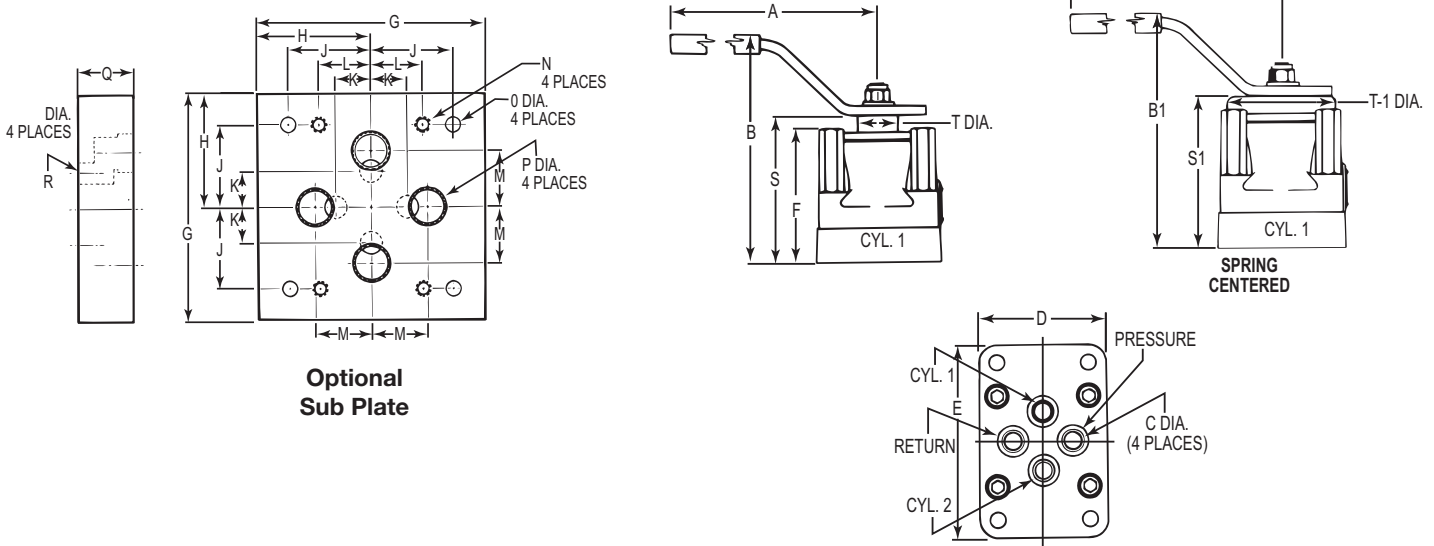

Optional Sub Plate

Valve Dimensions - inches (mm)

Size	A	A-1	B	B-1	C	D	E	F	S	S-1	T	T-1
1/2"	7.00 (178)	9.00 (229)	5.81 (148)	6.06 (154)	0.47 (12)	3.44 (87)	5.44 (138)	3.56 (90)	3.94 (100)	4.06 (103)	1.06 (27)	2.63 (67)
1"	10.0 (254)	14.0 (356)	7.63 (194)	8.81 (224)	0.75 (19)	4.75 (121)	6.88 (175)	4.81 (122)	5.13 (130)	6.19 (157)	1.25 (32)	3.56 (90)
1-1/2"	12.00 (305)	14.0 (356)	8.75 (222)	10.0 (254)	1.25 (32)	6.81 (173)	9.38 (238)	5.94 (151)	6.25 (159)	7.5 (191)	1.25 (32)	3.56 (90)

SubPlate Dimensions - inches (mm) Options:

Size	Port Type	Sub Plate p/n	G	H	J	K	L	M	N	O	P	Q	R	WT.
1/2"	NPT	34013	6.0 (152)	3.0 (76)	2.19 (56)	0.78 (20)	1.19 (30)	1.41 (36)	3/8 N.C.	0.41 (10)	1/2 NPT	1.25 (32)	0.44 (11)	11 3/4
	Socket Weld	34011	6.0 (152)	3.0 (76)	2.19 (56)	0.78 (20)	1.19 (30)	1.41 (36)	3/8 N.C.	0.41 (10)	.855 C'Bore	1.25 (32)	0.44 (11)	
1"	NPT	34015	8.0 (203)	4.0 (102)	2.88 (73)	1.25 (32)	1.81 (46)	1.97 (50)	1/2 N.C.	0.53 (13)	1" NPT	2.0 (51)	0.72 (19)	32 1/2
	Socket Weld	34012	8.0 (203)	4.0 (102)	2.88 (73)	1.25 (32)	1.81 (46)	1.97 (50)	1/2 N.C.	0.53 (13)	1.330 C'bore	2.0 (51)	0.72 (19)	
1-1/2"	NPT	34016	10.0 (254)	5.0 (127)	4.0 (102)	1.94 (49)	2.69 (68)	2.69 (68)	5/8 N.C.	0.53 (13)	1 1/2 NPT	2.0 (51)	1.22 (31)	49
	Socket Weld	34014	10.0 (254)	5.0 (127)	4.0 (102)	1.94 (49)	2.69 (68)	2.69 (68)	5/8 N.C.	0.53 (13)	1.915 C'bore	2.0 (51)	1.22 (31)	
2"	NPT	34018	10.0 (254)	5.0 (127)	4.0 (102)	1.94 (49)	2.69 (68)	2.69 (68)	5/8 N.C.	0.53 (13)	2" NPT	2.0 (51)	1.22 (31)	49
	Socket Weld	34017	10.0 (254)	5.0 (127)	4.0 (102)	1.94 (49)	2.69 (68)	2.69 (68)	5/8 N.C.	0.53 (13)	2.406 C'bore	2.0 (51)	1.22 (31)	

Product Configurator

Example: 376 5 M 3 W C 3

Series

376 Basic 376 series valve

Port Size

3 1/2" NPT ports
 5 1" NPT ports
 7 1-1/2" NPT ports

Style

M Manifold porting

Pressure Range

3 3,000 psi lubricated water or hydraulic oil

Working Media

W Lubricated water or hydraulic

Flow Pattern

C Closed center
 O Open center (tandem center)
 Q Closed center manipulator

Position

3 3-position

Options

See Supplemental Guide for complete list

Options

-MC Spring centering *
 -H 4,500 psi rated

* For 1" ported valve pressure rating 1,500 psi
 Not available on 1-1/2" ported valves