

DR7100 Series

Guided Radar (TDR) for Distance, Level & Volume of Liquids, Slurries and Solids



The new DR7100 with its more advanced design solutions has higher signal dynamics. Sharper Pulses measure thinner interfaces. The superior Time Base Stability allows better reproductibility, which translates to better reliability.

- **Easy Navigation & Viewing**
Choice of different Touch Screens:
(tank illustration, bargraph, oscilloscope...)
- **2-Wire**
Class I Div1, Zone 0 Installation
- **Special Process Separator for Extreme Conditions**
- **Probe Types and Materials for all Applications**

Designed to Perform Better than any Other TDR

Most Stable Measurement

Despite disturbances such as strongly agitated surfaces, foam and coating of the probe or fine dust in the tank, DR7100 will continue to measure where other devices fail.

Measures any Product ...

Most 2-wire TDR devices measure down to a dielectric of 1.5. As a result, many organic compounds are not measured properly. The DR7100 measures down to 1.4 (and even 1.1 using superior tank-bottom following mode).

... in any Application

5 different probes means there's not an application that we can't handle.

Makes Level Gauging Easier than Ever Wizard Works Wonders

Setting up a 2-wire level gauge couldn't be easier: Simply fit the gauge to the tank, wire it up and switch it on:

- Step 1 – The DR7100 tests itself to make sure its electronics are working perfectly.
- Step 2 – The DR7100s Wizard walks you through a simple series of questions to define your tank and the product you want to measure.
- Step 3 – That's all you need. Your DR7100 is already measuring.

Interactive Help

Not certain what to do? You don't need a handbook. Simply wait 10 seconds, the help screen will appear and tell you what to do.



Continuous Level Measurement

DR7100 Series

Specifications

Input

Function	Time Domain Reflectometry (TDR)
Parameter	Level, distance, volume and/or interface
Max. measuring range	Double rod 8mm / 0.3" 4m / 13ft Single rod 8mm / 0.3" 4m / 13ft Coaxial 22mm / 0.9" 6m / 20ft Double cable 4mm / 0.15" 35m / 115ft Single cable 4mm / 0.15" 35m / 115ft Single cable 8mm / 0.3" 35m / 115ft

Output Signal

Output signal 1	4 - 20mA HART® or 3.8 - 20.5 mA acc. to NAMUR NE 43
Output signal 2 (Optional)	4 - 20mA or 3.8 - 20.5 mA acc. to NAMUR NE 43
Accuracy	0.05% (rel. 20 mA; 20°C / 68°F)
Resolution	±2 µA
Temperature Drift	Typically 50 ppm/K
Error Signal	High: 22 mA; Low: 3.6 mA acc. to NAMUR NE 43
Max. Load	350 ohm

Measuring Accuracy - Reference conditions acc. to IEC770

Temperature	+20°C ±5°C / +68°F ±9°F
Pressure	1013 mbar abs. ±20 mbar 14.69 psig ±0.29 psig
Relative Humidity	60% ±15%
Resolution	1 mm / 0.04 "
Accuracy	In Direct Mode
Liquids	±3 mm / ±0.12" <i>when L < 10 m / 33 ft;</i> ±0.03% of measured distance, <i>when L > 10 m / 33 ft</i>
Powders	±20 mm / ±0.8"
Interface	±10 mm (εr Constant)

Application Conditions

Ambient Temp.	-40...+80°C / -40...+175°F; EEx i: -40...+60°C / -40...+140°F
Storage Temp.	-40...+85°C / -40...+185°F
Flange Temp.	-40...+200°C / -40...+392°F (Ex: refer to relevant device spec.)
Shock Resistance	100°C/min

Process Conditions

Operating Pressure	1...40 bar / -14.5...580 psig; subject to process connection and temp.
Dielectric Constant	≥ 1.4 Coaxial Probes ≥ 1.6 For single and Twin Probes
Vibration Resistance	IEC 68-2-6 and prEN 50178 (10...57Hz: 0.075 mm / 57...150 Hz: 1 g)
Protection Category	IP 66/67 equiv. to NEMA 6-6X

Human machine interface

Display	9 lines, 160x160 pixels in 8-step greyscale with 4-button keypad
Operating Languages	English, German, French, Italian, Spanish, Portugese, Japanese, Chinese (Mandarin), Russian

Mechanical Data

Housing	Aluminium
Wetted Parts	
Rod	Stainless steel (1.4404 / 316L); Hastelloy C-22 (2.4602)
Coaxial	Stainless steel (1.4404 / 316L); Hastelloy C-22 (2.4602)
Cable (4mm / 0.15")	Stainless steel (1.4401 / 316); Hastelloy C-22 (2.4602)
Process Fitting	Stainless steel (1.4404 / 316L); Hastelloy C-22 (2.4602)
Gaskets	Viton (-40...+150°C / -40...+300°F); Kalrez 6375 (-20...+150°C / -5 ...+300°F)

Process Connection

Thread	G 3/4" ... 1 1/2"; NPT 3/4" ... 1 1/2"
Flange	DN 25...DN 150 (PN 40 / PN 16); 1" ... 8" (150 lb / 300 lb); 10 K (40...100A)

Electrical Connection - 2-Wire Power Supply

Terminals Output 1	Non-Ex/ EEx i 24 VDC (14 ... 30 VDC) EEx d 24 V DC (20 ... 36 VDC)
Terminals Output 2	Non-Ex/ EEx i/EEx d 24 VDC (10 ... 30 VDC)
Cable Entry Terminals	M20x1.5; 1/2 NPT; G 1/2" 0.5...1.5 mm ²

Approvals

ATEX	Ex ia	ATEX II 1 G D or II 1/2 G D or II 2 G D; KEMA 04ATEXxxxxX
	Ex d	EEx ia IIC T3 ... T6 T65°C ... T90°C IP 6X ATEX II 1/2 G D or II 2 G D; EEx d [ia] IIC T6 ... T3 T65°C ... T90°C IP 6X
FM	Ex ia	Intrinsically Safe (IS)
CSA		IS CL I, DIV 1, GR A,B,C,D DIP CL II, III, DIV 1, GR E,F,G NI ANI CL I, DIV 2, GR A,B,C,D (FM Only) DIP CL II, III, DIV 1 GR E,F,G
		Sensor Probe suitable for use in DIV 1 or ZONE 0 CL I, Zone 0, AEx ia IIC CL I, Zone 2, GR IIC CL I, Zone 0, Ex ia IIC T6, Ta = 60° C
	Ex d	Explosion Proof (XP) XP CL I, DIV 1, GR A,B,C,D (FM Only) CL I, DIV 2, GR A,B,C,D DIP CL II, III, DIV 1, GR E,F,G NI ANI CL I, DIV 2, GR A,B,C,D (FM Only) DIP CL II, III, DIV 2 GR F,G
		Sensor Probe suitable for use in DIV 1 or ZONE 0 CL I, Zone 0, AEx d ia IIC CL I, Zone 2, GR IIC CL I, Zone 0, Ex d ia IIC T6, Ta = 60° C

Continuous Level Measurement

DR7100 Series

Model Numbering

DR7100	4		
Approval		Approval	
0	without	5	ATEX II G/D 1/2, 2 EEx d ia IIC T6 + WHG
1	WHG (overflow protection certificate)	6	FM / CSA IS Cl. I Div. 1 Gr. A-G
2	ATEX II G/D 1, 1/2, 2 EEx ia IIC T6	7	FM / CSA XP Cl. I Div. 1 Gr. A-G
3	ATEX II G/D 1/2, 2 EEx d ia IIC T6	8	FM / CSA General purpose
4	ATEX II G/D 1, 1/2, 2 EEx ia IIC T6 + WHG		
Material Process Connection and Probe			
0	316L / 1.4404		
1	Hastelloy C-22 / 2.4602 (not for probes 4-5-D-E)		
Probe			
0	Single rod Ø 8 mm / 0.31 inch max. 4 m / 13.12 ft		
1	Double rod Ø 8 mm / 0.31 inch max. 4 m / 13.12 ft		
2	Coax Ø 22 mm / 0.87 inch max. 6 m / 19.69 ft		
3	Single cable Ø 4 mm / 0.16 inch max. 35 m / 114.83 ft		
4	Single cable Ø 8 mm / 0.31 inch max. 35 m / 114.83 ft		
5	Double cable Ø 4 mm / 0.16 inch max. 35 m / 114.83 ft		
A	NO probe - (Single rod Ø 8 mm / 0.31 inch max. 4 m / 13.12 ft)		
B	NO probe - (Double rod Ø 8 mm / 0.31 inch max. 4 m / 13.12 ft)		
C	NO probe - (Single cable Ø 4 mm / 0.16 inch max. 35 m / 114.83 ft)		
D	NO probe - (Single cable Ø 8 mm / 0.31 inch max. 35 m / 114.83 ft)		
E	NO probe - (Double cable Ø 4 mm / 0.16 inch max. 35 m / 114.83 ft)		
Probe end type			
0	without		
1	Counterweight Ø 12 mm / 0.47 inch x 100 mm / 3.94 inch (Single cable Ø 8 mm / 0.31 inch)		
2	Counterweight Ø 38 mm / 1.5 inch x 245 mm / 9.65 inch (Single cable Ø 8 mm / 0.31 inch)		
3	Counterweight Ø 20 mm / 0.79 inch x 100 mm / 3.94 inch (Single cable Ø 4 mm / 0.16 inch)		
4	Counterweight Ø 38 mm / 1.5 inch x 60 mm / 2.36 inch (Double cable Ø 4 mm / 0.16 inch)		
A	turnbuckle		
B	chuck		
C	threaded end		
D	crimped end		
E	open end		
Feedthrough/Temperature/Sealing			
0	Standard / -40°C...+150°C / Viton GLT		
1	Standard / -20°C...+150°C / Kalrez 6375		
Process connection EN		Process connection EN	
0	without	6	DN 50 PN 40 Form B1 EN1092
1	G 3/4 A ISO229	7	DN 80 PN 40 Form B1 EN1092
2	G 1 A ISO229	8	DN 100 PN 16 Form B1 EN1092
3	G 1 1/2 A ISO229	A	DN 100 PN 40 Form B1 EN1092
4	DN 25 PN 40 Form B1 EN1093	B	DN 150 PN 16 Form B1 EN1092
5	DN 40 PN 40 Form B1 EN1092	C	DN 150 PN 40 Form B1 EN1092
Process connection ANSI		Process connection ANSI	
0	without	8	2" 300 lb RF ANSI B16.5
1	3/4" NPT	A	3" 150 lb RF ANSI B16.5
2	1" NPT	B	3" 300 lb RF ANSI B16.5
3	1 1/2" NPT	C	4" 150 lb RF ANSI B16.5
4	1" 150 lb RF ANSI B16.6	D	4" 300 lb RF ANSI B16.5
5	1 1/2" 150 lb RF ANSI B16.5	E	6" 150 lb RF ANSI B16.5
6	1" 1/2 300 lb RF ANSI B16.5	F	8" 150 lb RF ANSI B16.5
7	2" 150 lb RF ANSI B16.5		
Process connection other			
0	without		
5	10K 40A RF JIS B2238		
6	10K 50A RF JIS B2238		
7	10K 80A RF JIS B2238		
8	10K 100A RF JIS B2238		
Output			
0	Output: 4...20mA (HART)		
1	Output: 4...20mA (HART) - INTERFACE		
2	2 Outputs: 4...20mA (HART) + 4...20mA		
3	2 Outputs: 4...20mA (HART) + 4...20mA - INTERFACE		
Housing/Cable entry/Cable gland			
0	Aluminium / M20x1.5 / without		
1	Aluminium / 1/2 NPT / without		
2	Aluminium / G 1/2 / without		
3	Aluminium / M20x1.5 / Plastic (non-EEEx: black, EEEx i: blue)		
4	Aluminium / M20x1.5 / Metall (only for EEEx d devices)		
Housing option			
0	without		
2	Weather protection		
HMI (display and keys ... English is default second language for 2-3-4-5-6-7-8-A)			
0	without		
1	English (second language: German)		
2	German		
3	French		
4	Italian		
5	Spanish		
6	Portuguese		
7	Japanese		
8	Chinese (Mandarin)		
A	Russian		
Version			
1	Drexelbrook Standard		
Dummy			
0	without		
Material certificate			
0	without		
1	3.1.B certificate: wetted parts		
2	3.1.B certificate: parts under pressure		
3	Positive Material Identification (PMI): wetted parts		
4	Positive Material Identification (PMI): parts under pressure		
5	2.1. material conformity certificate		
Hydraulics control certificate			
0	without		
1	2.3. Hydraulics test certificate		
2	3.1.B Hydraulics test certificate		
Calibration certificate			
0	without		
1	Calibration certificate		
Certificate (Miscellaneous)			
0	without		
1	2.1. Order conformity certificate		
Drawing /TAG Number			
0	without		
1	Drawing (overall dimensions)		
2	Tag No. stainless steel plate		
3	Drawing + TAG No. Stainless steel		
DR7100	4	1	0
<i>Subject to Change Without Notice</i>			

Continuous Level Measurement

DR7100 Series

Dimensions - mm / Inch

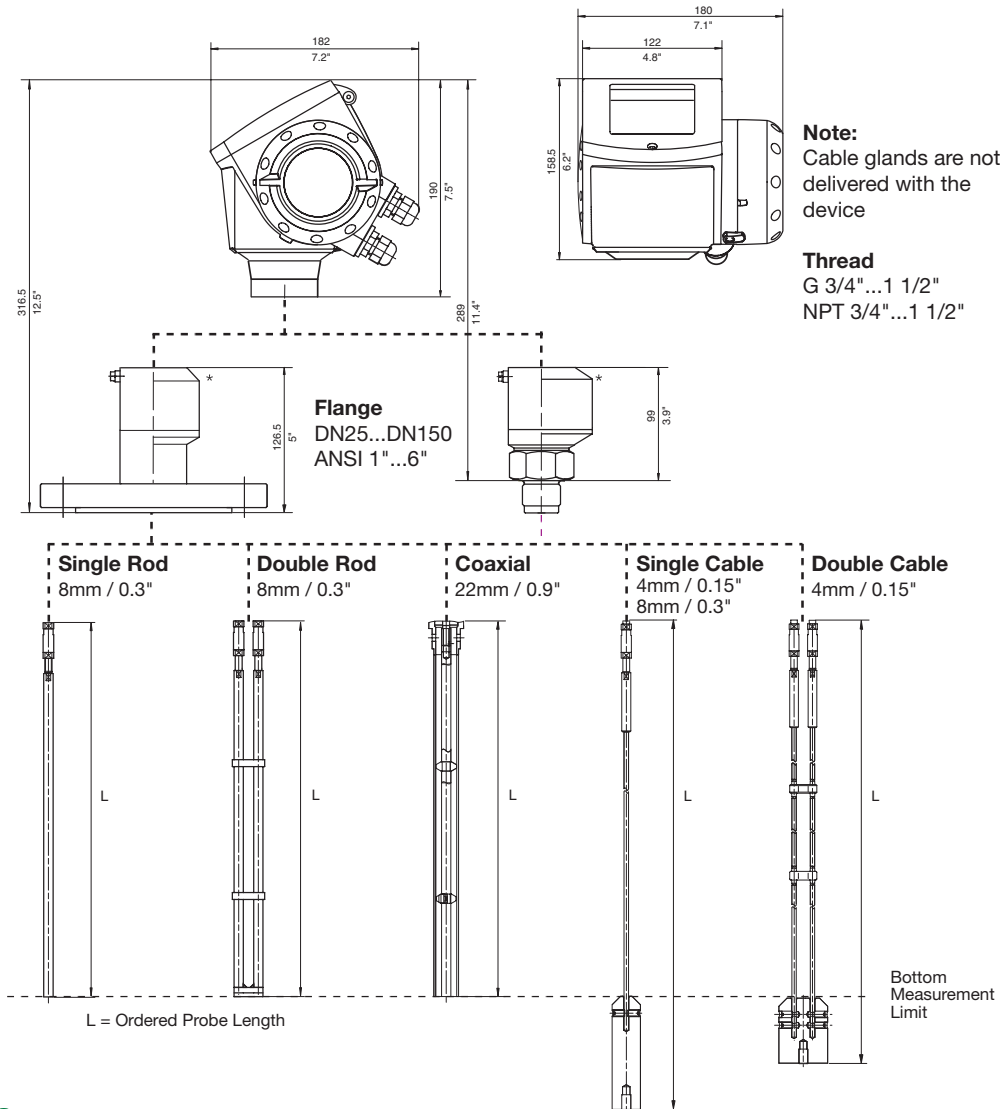

Weights

Housing and Connection (316 SS)	[kg]	[lb]
Housing	3.3	7.3
Flange connection DN 25...80 / ANSI 1"...3"	4...7	8.8...15.4
Flange connection DN 100...150 / ANSI 4"...6"	7...12	15.4...26.5
Thread connection	3	6.6
Probes	[kg/m]	[lb/ft]
Single cable 4mm or 0.15"	0.12	0.08
Single cable 8mm or 0.3"	0.41	0.28
Double cable 4mm or 0.15"	0.24	0.16
Single rod 8mm or 0.3"	0.41	0.28
Double rod 8mm or 0.3"	0.82	0.56
Coaxial 22mm or 0.9"	0.79	0.53

Note:
Wide range of counterweights and anchoring solutions available.

* Only single cable 8mm / 0.3" (solids application)

Continuous Level Measurement

DR7100 Series

Measurement Limits

Probes	Top Dead Zone $\epsilon r = 80^*$	Bottom Dead Zone $\epsilon r = 80^*$	Top Dead Zone $\epsilon r = 2.3^*$	Bottom Dead Zone $\epsilon r = 2.3^*$
Double Rod	125 mm / 4.9"	10 mm / 0.4"	165 mm / 6.5"	50 mm / 1.95"
Single Rod	200 mm / 7.9"	10 mm / 0.4"	250 mm / 9.9"	50 mm / 1.95"
Coaxial	10 mm / 0.4"	10 mm / 0.4"	10 mm / 0.4"	50 mm / 1.95"
Double Cable	125 mm / 4.9"	10 mm / 0.4"	165 mm / 6.5"	50 mm / 1.95"
Single Cable 8 mm/0.3"	200 mm / 7.9"	10 mm / 0.4"	250 mm / 9.9"	50 mm / 1.95"
Single Cable 4 mm/0.15"	200 mm / 7.9"	10 mm / 0.4"	250 mm / 9.9"	50 mm / 1.95"

* 80 is ϵr of water; 2.3 is ϵr of oil

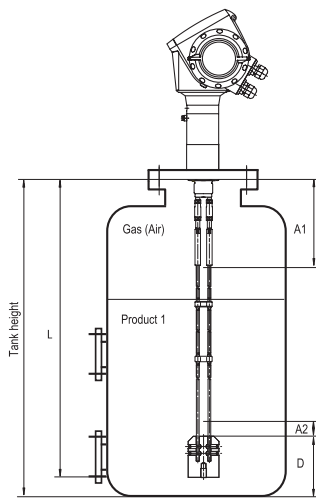

- A1 - Top dead zone**
 Minimum distance from flange to top limit of measuring range.
- A2 - Bottom dead zone**
 Length at end of probe, where measurement is not possible.
- D - non measurement zone**
 Zone where measurement cannot be taken.
- L - Probe length**
 Length specified by customer in the order.

Probe Selection

	Double Rod	Single Rod	Coaxial	Double Cable 8 mm / 26'	Single Cable 8 mm / 0.3"	Single Cable 4 mm / 0.15"
Maximum Tank Height						
4 m / 13 ft	◆	◆				
6 m / 20 ft			◆	◆		
35 m / 115 ft					◆	◆
Liquids						
Liquid Application	◆	◆	◆	◆		◆
LPG, LNG	◆		◆	◆		
Highly Viscous Liquids		◆				◆
Highly Crystallising Liquids		◆				◆
Highly Corrosive Liquids	◆	◆	◆			◆
Foam		◆				◆
Agitated Liquids	◆		◆	◆*		◆*
Spray in Tank			◆			
Storage Tanks	◆	◆	◆	◆		◆
Bypass Chamber	◆	◆	◆	◆		◆
Small Diameter Nozzles	◆		◆	◆		
Long Nozzles	◆		◆	◆		
Stilling Wells	◆	◆	◆	◆		◆
Interface Measurement	◆		◆	◆		
Solids / Granulars					◆	

* with anchor fitting

Continuous Level Measurement

Other Great Solutions By: DREXELBROOK®

Universal III™ 509-75 Series

Level Transmitter



DM330 Series

Magnetostrictive Liquid Level Sensor



Wireless Interface Solutions

Wireless Analog / Digital Link

Tube Mount NEMA 4x Transmitter DIN-Rail / Receiver Set



2867021-DRX

2867034-DRX



OMNEX
Trusted Wireless

USonic™ Series

Ultrasonic Level Transmitter



AMETEK® DREXELBROOK®

205 Keith Valley Road, Horsham, PA 19044 U.S.A.

Tel: 215-674-1234 Fax: 215 674-2731

Email: drexelbrook.info@ametek.com

Web: www.drexelbrook.com